

# InGaAs PIN photodiode G8422/G8372/G5852 series

Long wavelength type (up to 2.1  $\mu\text{m}$ )

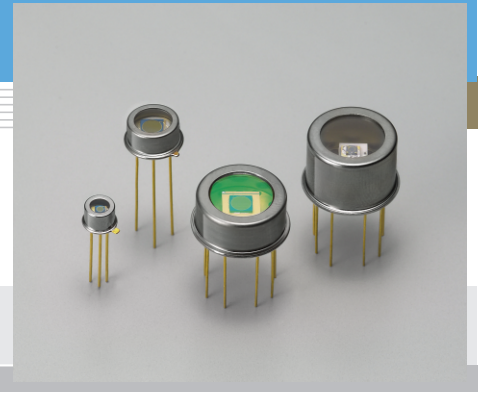

## Features

- Cut-off wavelength: 2.1  $\mu\text{m}$
- 3-pin TO-18 package: low price
- TE-cooled type TO-8 package: low dark current
- Active area:  $\phi 0.3$  to  $\phi 3$  mm

## Applications

- Gas analyzer
- Water content analyzer
- NIR (Near Infrared) photometry

### Specifications / Absolute maximum ratings

Type No.	Dimensional outline	Package	Cooling	Active area (mm)	Absolute maximum ratings				
					Thermistor power dissipation (mW)	TE-cooler allowable current (A)	Reverse voltage $V_R$ (V)	Operating temperature $T_{opr}$ ( $^{\circ}\text{C}$ )	Storage temperature $T_{stg}$ ( $^{\circ}\text{C}$ )
G8422-03	①	TO-18	Non-cooled	$\phi 0.3$	-	-	-	-40 to +85	-55 to +125
G8422-05				$\phi 0.5$					
G8372-01				$\phi 1$					
G8372-03	②	TO-5		$\phi 3$					
G5852-103	③	TO-8	One-stage TE-cooled	$\phi 0.3$	0.2	1.5	2	-40 to +70	-55 to +85
G5852-11				$\phi 1$					
G5852-13				$\phi 3$					
G5852-203	④	TO-8	Two-stage TE-cooled	$\phi 0.3$	0.2	1.0	2	-40 to +70	-55 to +85
G5852-21				$\phi 1$					
G5852-23				$\phi 3$					

### Electrical and optical characteristics (Typ. unless otherwise noted)

Type No.	Measurement condition	Spectral response range $\lambda$ ( $\mu\text{m}$ )	Peak sensitivity wavelength $\lambda_p$ ( $\mu\text{m}$ )	Photo sensitivity $S_{\lambda=\lambda_p}$ (A/W)	Dark current $I_D$ ( $V_R=1$ V)		Cut-off frequency $f_c$ ( $V_R=1$ V, $R_L=50$ $\Omega$ ) (MHz)	Terminal capacitance $C_t$ ( $V_R=1$ V, $f=1$ MHz) (pF)	Shunt resistance $R_{sh}$ ( $V_R=10$ mV) (M $\Omega$ )	$D^*$ $\lambda=\lambda_p$ (cm $\cdot$ Hz $^{1/2}$ /W)	NEP $\lambda=\lambda_p$ (W/Hz $^{1/2}$ )
	Element				Typ. (nA)	Max. (nA)					
	Temperature $T$ ( $^{\circ}\text{C}$ )										
G8422-03	25	0.9 to 2.1	1.95	1.2	55	550	100	8	0.9	$2.5 \times 10^{11}$	$1.5 \times 10^{-13}$
G8422-05					125	1250	80	20	0.3		$2.5 \times 10^{-13}$
G8372-01					500	5000	40	80	0.1		$4 \times 10^{-13}$
G8372-03					5 ( $\mu\text{A}$ )	50 ( $\mu\text{A}$ )	3	800	0.01		$1.5 \times 10^{-12}$
G5852-103	-10	0.9 to 2.07	1.95	1.2	5.5	55	100	8	9	$8 \times 10^{11}$	$5 \times 10^{-14}$
G5852-11					50	500	40	80	1		$1 \times 10^{-13}$
G5852-13					500	5000	3	800	0.1		$4 \times 10^{-13}$
G5852-203	-20	0.9 to 2.05	1.95	1.2	3	30	100	8	18	$1.2 \times 10^{12}$	$3 \times 10^{-14}$
G5852-21					25	250	40	80	2		$8 \times 10^{-14}$
G5852-23					250	2500	3	800	0.2		$3 \times 10^{-13}$

G8422/G8372/G5852 series may be damaged by Electro Static Discharge, etc. Be carefull when using G8422/G8372/G5852 series.

■ Spectral response

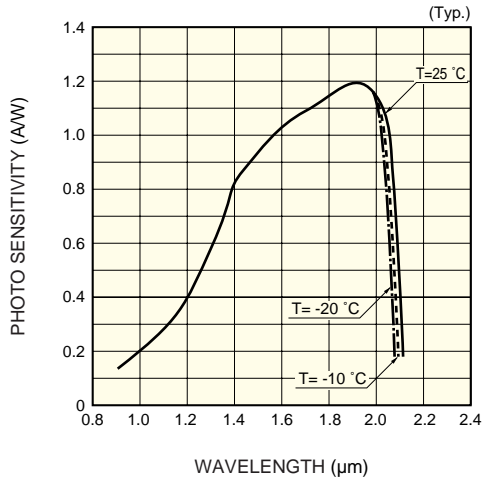

■ Photo sensitivity temperature characteristic

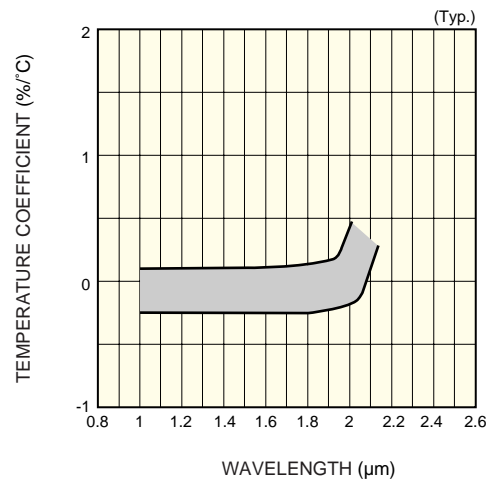

■ Dark current vs. reverse voltage

Non-cooled type

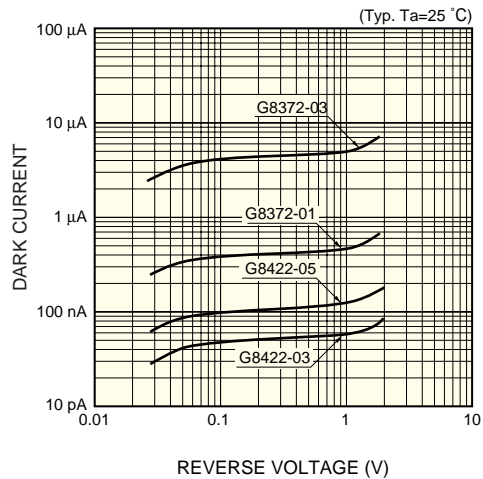

TE-cooled type

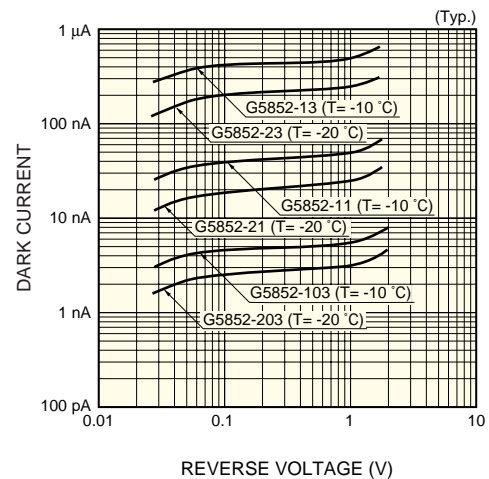

■ Terminal capacitance vs. reverse voltage

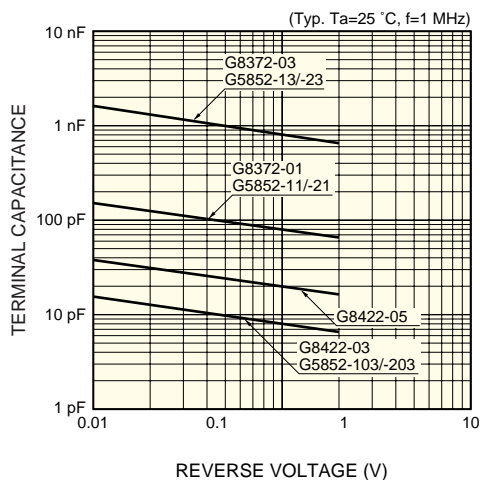

■ Shunt resistance vs. element temperature

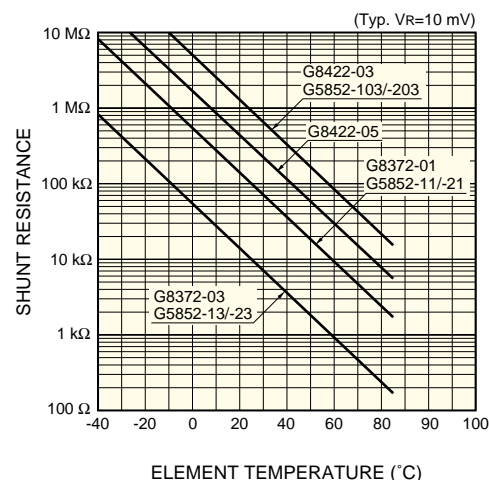

■ Thermistor temperature characteristic

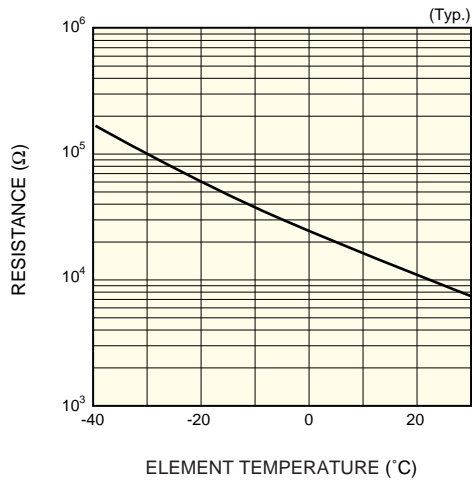

KIRDB0116EA

■ Cooling characteristics of TE-cooler

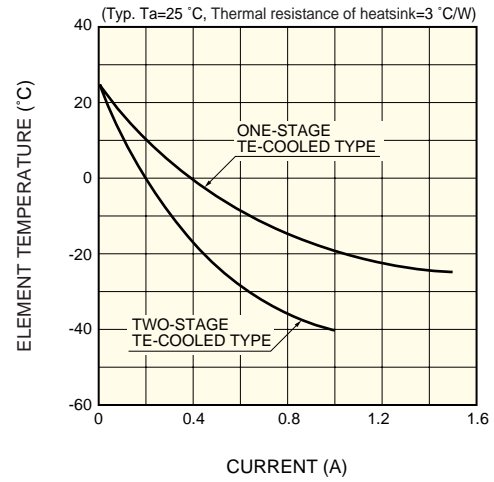

KIRDB0231EA

■ Current vs. voltage characteristics of TE-cooler

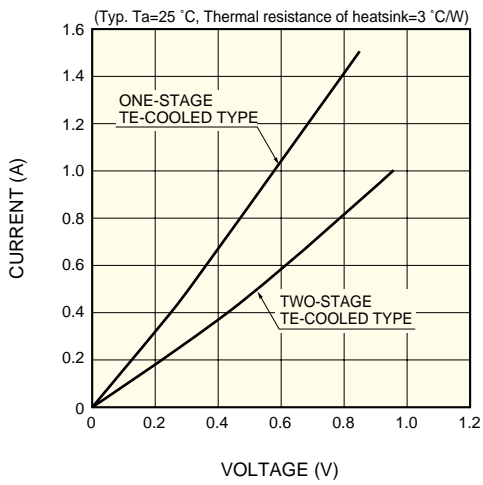

KIRDB0115EB

# InGaAs PIN photodiode G8422/G8372/G5852 series

Dimensional outline (unit: mm)

① G8422-03/-05, G8372-01

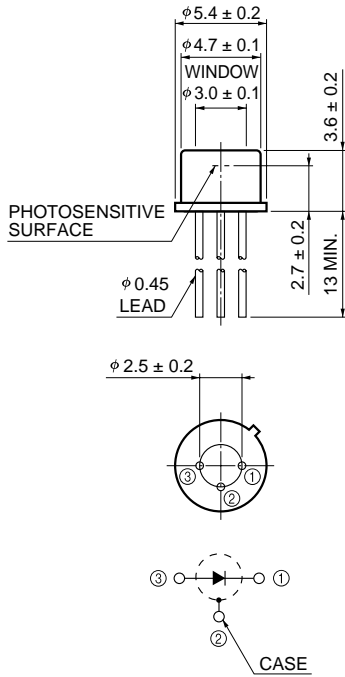

KIRDA0150EA

② G8372-03

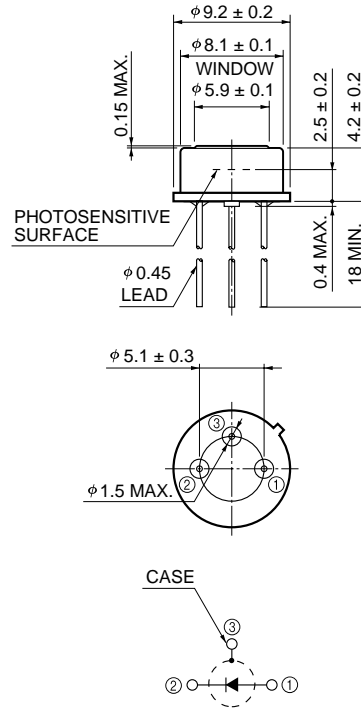

KIRDA0151EA

③ G5852-103/-11/-13

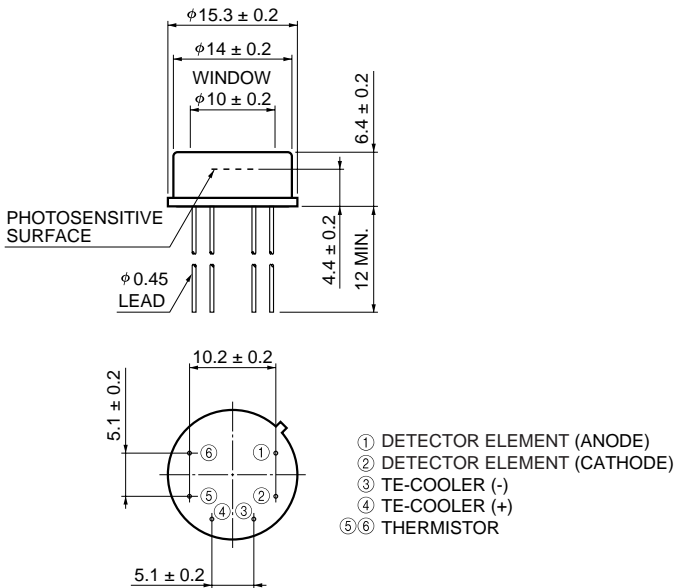

KIRDA0029EB

④ G5852-203/-21/-23

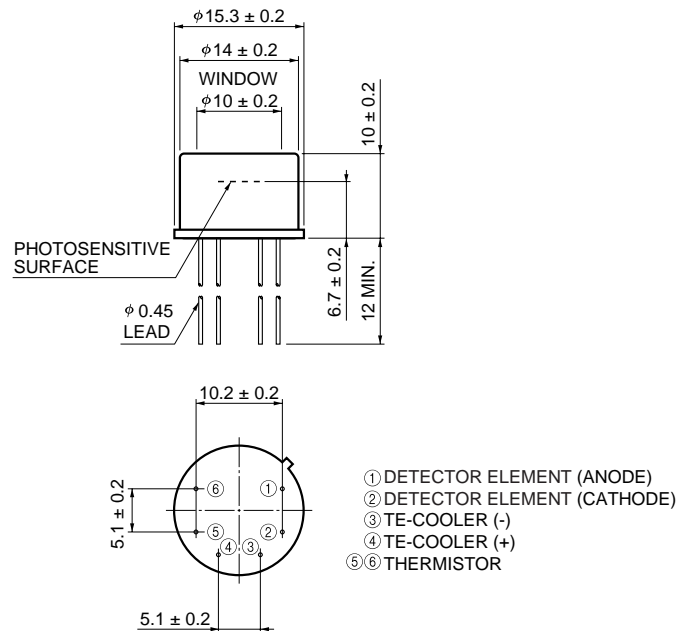

KIRDA0031EB

**HAMAMATSU** Information furnished by HAMAMATSU is believed to be reliable. However, no responsibility is assumed for possible inaccuracies or omissions. Specifications are subject to change without notice. No patent rights are granted to any of the circuits described herein. ©2004 Hamamatsu Photonics K.K.

HAMAMATSU PHOTONICS K.K., Solid State Division

1126-1 Ichino-cho, Hamamatsu City, 435-8558 Japan, Telephone: (81) 053-434-3311, Fax: (81) 053-434-5184, <http://www.hamamatsu.com>

U.S.A.: Hamamatsu Corporation, 360 Foothill Road, P.O.Box 6910, Bridgewater, N.J. 08807-0910, U.S.A., Telephone: (1) 908-231-0960, Fax: (1) 908-231-1218

Germany: Hamamatsu Photonics Deutschland GmbH, Arzbergerstr. 10, D-82211 Herrsching am Ammersee, Germany, Telephone: (49) 08152-3750, Fax: (49) 08152-2658

France: Hamamatsu Photonics France S.A.R.L.: 8, Rue du Saule Trapu, Parc du Moulin de Massy, 91882 Massy Cedex, France, Telephone: 33-(1) 69 53 71 00, Fax: 33-(1) 69 53 71 10

United Kingdom: Hamamatsu Photonics UK Limited, 2 Howard Court, 10 Tewin Road, Welwyn Garden City, Hertfordshire AL7 1BW, United Kingdom, Telephone: (44) 1707-294888, Fax: (44) 1707-325777

North Europe: Hamamatsu Photonics Norden AB, Smidesvägen 12, SE-171 41 Solna, Sweden, Telephone: (46) 8-509-031-00, Fax: (46) 8-509-031-01

Italy: Hamamatsu Photonics Italia S.R.L.: Strada della Moia, 1/E, 20020 Arese, (Milano), Italy, Telephone: (39) 02-935-81-733, Fax: (39) 02-935-81-741

Cat. No. KIRD1047E03  
Mar. 2004 DN